

Front Mount Cylinder "MF"

MODEL	TYPE	STANDARD STROKES	"A"	PISTON AREA
L20	_,D	25mm, 50mm, 75mm, 100mm	55,0(2.17")	PUSH 12,57 cm ² (1.95 in ²) PULL 8,77 cm ² (1.36 in ²)

	Standard Threads	"EM" Option
"B"	G1/4	#4 SAE
"C"	M16X2	5/8-18
"D"	M8X1.25	5/16-24

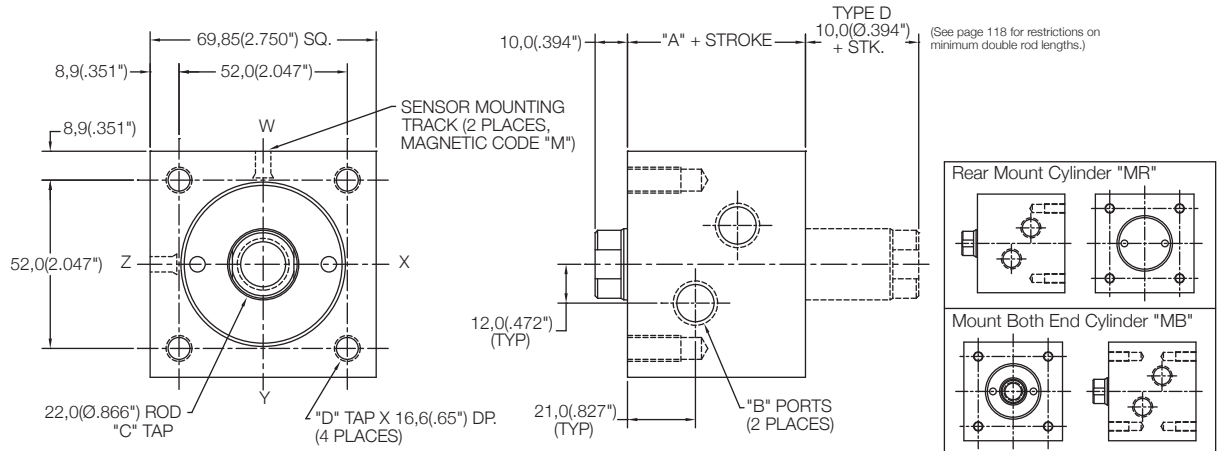

Thru Mount Cylinder "MT"

MODEL	TYPE	STANDARD STROKES	"A"	PISTON AREA
L20	_,D	25mm, 50mm, 75mm, 100mm	55,0(2.17")	PUSH 12,57 cm ² (1.95 in ²) PULL 8,77 cm ² (1.36 in ²)

	Standard Threads	"EM" Option
"B"	G1/4	#4 SAE
"C"	M16X2	5/8-18

